

Walcut Model 24E

Walcut Model 24E Carriage and Locking block Assembly Dwg & parts list

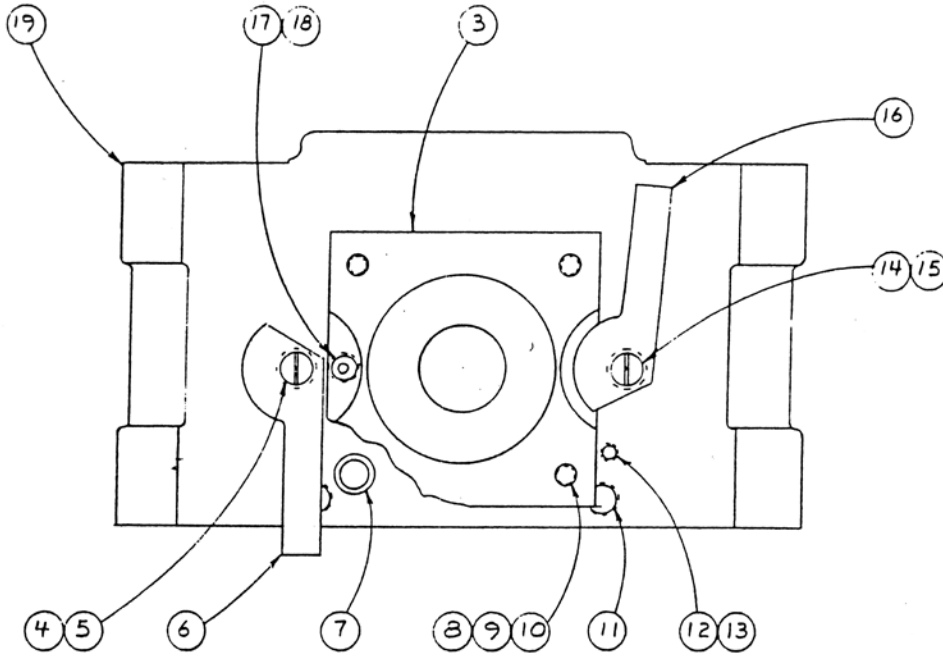

When ordering parts for a Mod. 30 Wall Saw, specify that items 1, 2 & 19 are for a Mod. 30 Wall Saw.

CARRIAGE & MOTOR LOCKING BLOCK ASSY.

APPROV	Sweatt	7/20/87.	DATE
1 TOLERANCES		GDM inc.	
X	00	152 AERO CAMPINO	
XX	03	GOLETA, CALIF. 93017	
XXX	01	805 - 968-2513	
X/Y	1/32	2 ALL MACHINED SURFACES TO HAVE A 125 FINISH	
SIZE	DWG. NO	REV	
B	5022	N/C	
WEIGHT	SCALE 1/2 x	SMT. 1	OF 1

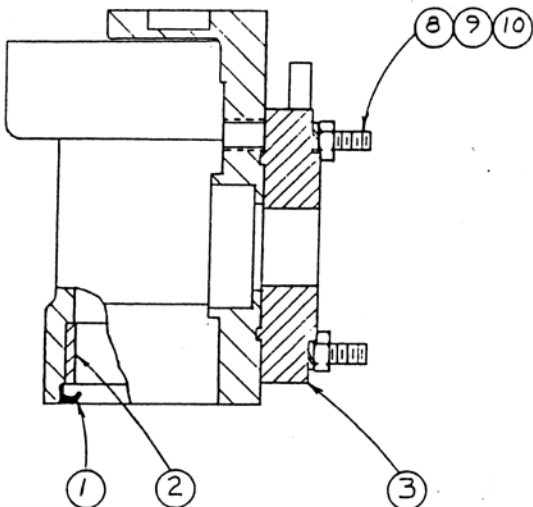

ITEM	QTY	DESCRIPTION	PART NO.
19	1	CARRIAGE	5011
18	2	SOC. HEAD SET SCREW	3/8- 16 x 7/16
17	2	3/8-16 HELI-COIL	3585-6CN 0375
16	1	R.H. CAMLOCK (L.H. THD.)	5015-1
15	1	R.H. CAMLOCK SCREW (L.H. THD.)	5016-1
14	1	1/2-20 HELI-COIL (L.H. THD.)	4291-8CN 0500
13	2	CAMLOCK SPRING PLUNGERS	100-25 SPPL
12	2	1/4- 20 HELI-COIL	3585-4CN 0375
11	3	3/8- 16 HELI-COIL	3585-6CN 0750
10	4	NUT	5/16-18
9	4	LOCK WASHER	5/16
8	4	MOTOR MOUNTING BOLT	5018
7	4	MOTOR LOCATING BUSHINGS	5010
6	1	L.H. CAM LOCK (R.H. THD.)	5015-2
5	1	L.H. CAM LOCK SCREW (R.H. THD.)	5016-2
4	1	1/2- 20 HELI-COIL (R.H. THD.)	3591-8CN 0500
3	1	MOTOR LOCKING BLOCK	5014
2	4	COLUMN BUSHINGS	B 2428-8
1	4	COLUMN SEAL	C/R 14855