

# Walcut Model 30E

Walcut Model 30E - Gearbox blade Assembly 400 cyc- pg 1/2

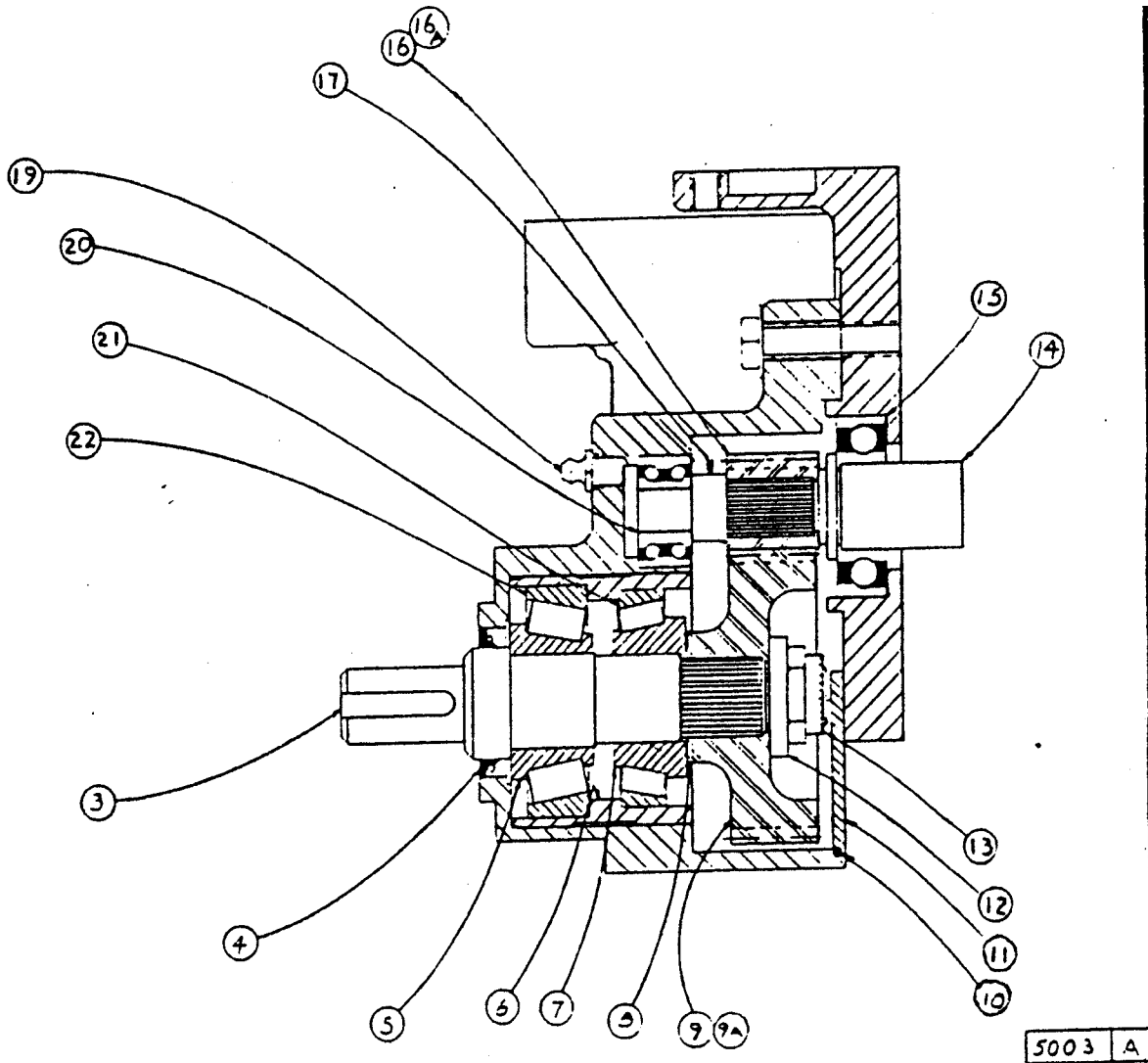

GEARBOX, BLADE ASSEMBLY  
400 CYCLE - MODEL 24

SWAPP 8/20/05	
GDM inc. 132 ALPO DR GOLETA, CA 93146	
D	5003 A
KAT FULL VIT	

# Walcut Model 30E

Walcut Model 30E - Gearbox blade Assembly 400 cyc- pg 2/2

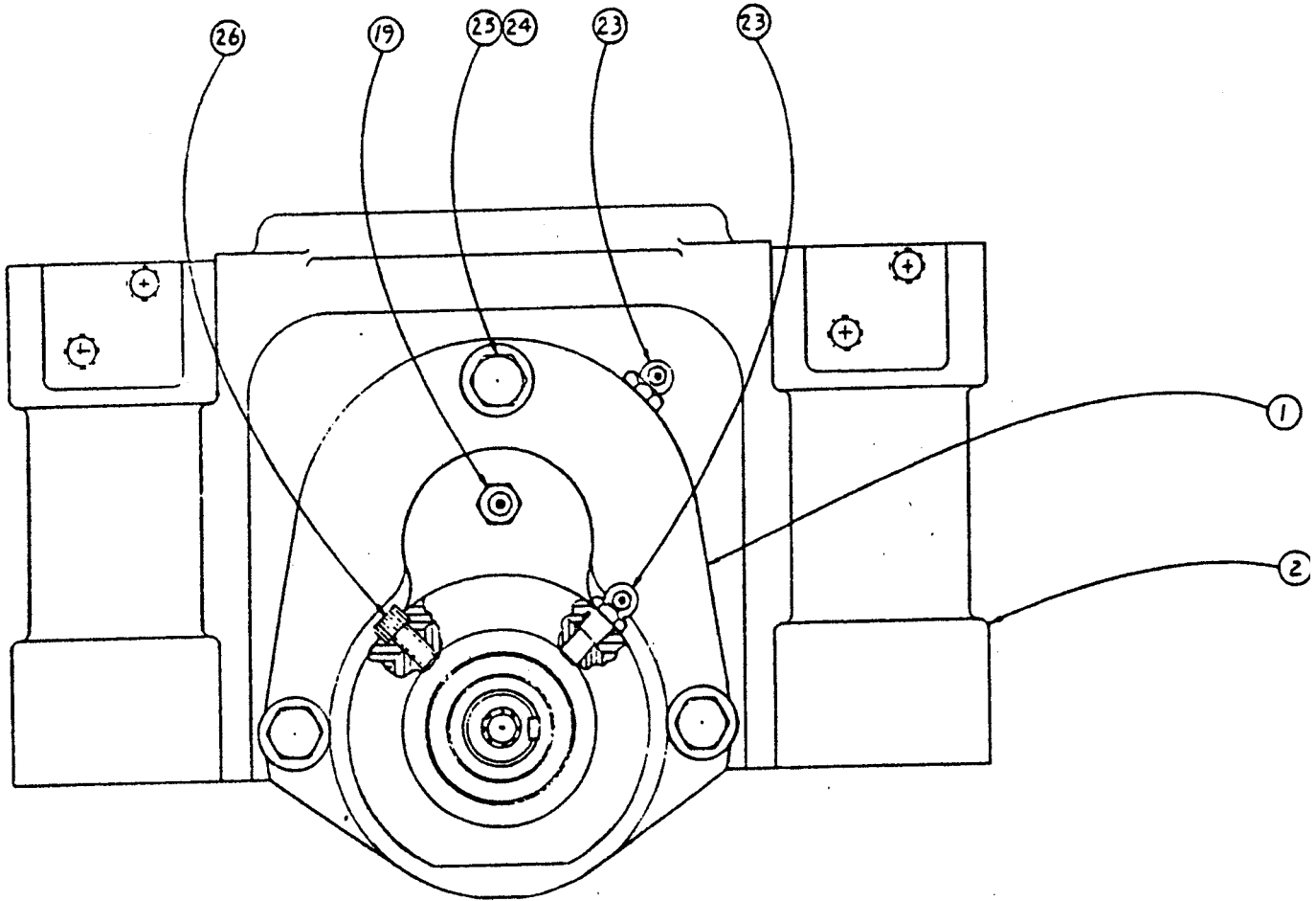

26	3	SOCKET HEAD CAP SCREW	1/4-20 X 1/2
25	3	HEX HEAD MACHINE SCREW	3/8-16 X 1 1/2
24	3	WASHER	3/8 SAE
23	2	90° GREASE FITTING	1613-B (ALEMITE)
22	1	TIMKEN BEARING CUP	2631
21	1	TIMKEN BEARING CUP	15245
20	1	FRONT BEARING (PINION GEAR)	5501
19	1	GREASE FITTING	1610-BL (ALEMITE)
18			
17	1	PINION GEAR SPACER	5013
16A	1	PINION GEAR (1400 RPM)	5009
16	1	PINION GEAR (800 RPM)	5008
15	1	REAR BEARING (PINION GEAR)	205
14	1	PINION GEAR SHAFT	5007
13	1	SELF LOCKING JAM NUT	5/8-11
12	1	WASHER	26590 (WELSH)
11	1	GEAR COVER	H-269
10	1	"O" RING	A-151
9A	1	DRIVE GEAR (1400 RPM)	5006
9	1	DRIVE GEAR (800 RPM)	5005
8		ARBOR SPACERS (AS REQD.)	1 X 1 1/2 X .002
7	1	TIMKEN BEARING CONE	15100
6	1	INSERT	H 261
5	1	TIMKEN BEARING CONE	2682
4	1	SHAFT SEAL	C/R 12336
3	1	BLADE DRIVE SHAFT	H 262
2	1	CARRIAGE	5011
1	1	GEARBOX	5004